

N=Number of Positions

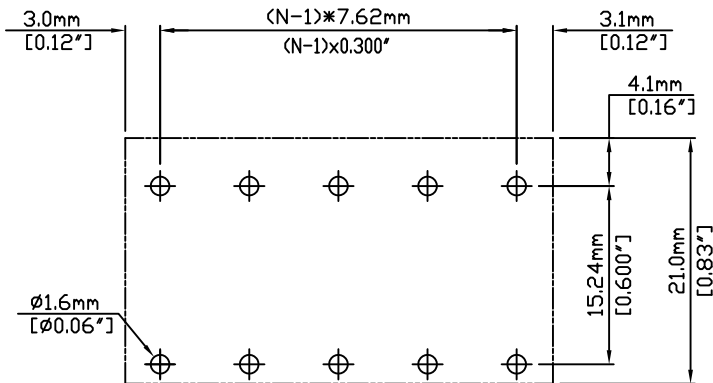
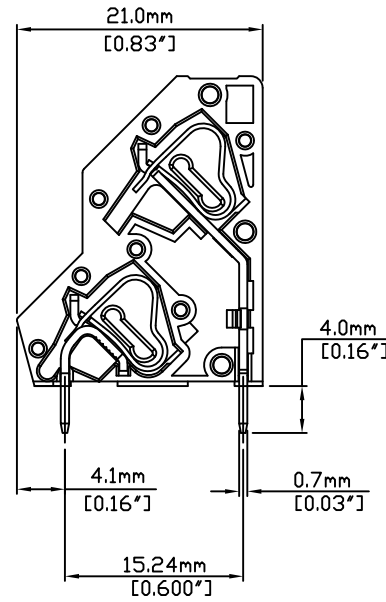

PCB. LAYOUT

Material:	
Contact Solder Pin:	Brass, Tin Plated
Wire Retention Spring:	Stainless Steel
Insulating Body:	Polyamide, UL94V-0, Grey
Electrical	
Voltage Rating:	300 VAC
Current rating:	10 AMPS
Withstand Voltage:	1500 VAC, Test time 60 sec
Wire Range:	12-28 AWG
Mechanical	
Operating Temperature:	-40°C to +105°C -40°F to +221°F
Soldering Temperature:	260°C, 500°F for 5 seconds
Safety Approval:	CE, UL, IEC

Part Number Configuration.

EB407-XX-802

Number of Positions: 8
Color: Grey

(Other Color Options Available)
Please consult Factory

MAX NUMBER OF POSITIONS = 16

UNLESS OTHERWISE SPECIFIED BREAK ALL SHARP EDGES AND DEBURR ALL HOLES	TITLE: 7.62mm SPACING, SCREWLESS BLOCK
LIMITS: UNLESS OTHERWISE SPECIFIED HUND.±.02 FRACT.±1/64 THOU.±.005 ANGLE±1°	SCALE: THIS IS A CONFIDENTIAL DRAWING AND MUSTBE TREATED AS SUCH. NO DISTRIBUTION IS ALLOWED WITHOUT WRITTEN APPROVAL BY EBYP ELECTRO INC.
	PLAINVIEW, NY 11803

IMPORTANT DISCLAIMER: All information provided on this print is for reference. Always perform your own tests and acquire samples and further information to determine product suitability. While we make effort to provide accurate information, we cannot be responsible for errors either of omission or typographical. EBYP Electro, Inc. assumes no responsibility for the use or suitability of any product. All products and specifications are subject to change without prior written notice.

METRIC LIMITS ONE PLACE ±0.3 TWO PLACES ±0.10 ANGLE ±1°	DRAWN: JM CHECKED: _____ APPROVED: _____	DATE: 08/02/07 DATE: _____ DATE: _____	SIZE: A	DRAWING NUMBER: EB407-XX-802	REV.
--	--	--	---------	---------------------------------	------