

Material:	
Contact Solder Pin:	Brass, Tin Plated
Insulating Body:	Polycarbonate, UL94V-0, Black
Terminal Screw:	#6-32, Combo Head, Steel Zinc Plated
Electrical	
Voltage Rating:	300 VAC
Current rating:	20 AMPS
Withstand Voltage:	1500 VAC, Test time 60 seconds
Wire Range:	12-24 AWG
Mechanical	
Torque:	10 Lbs-in. Max.
Operating Temperature:	-40°C to +105°C -40°F to +221°F
Soldering Temperature:	260°C, 500°F for 5 seconds max.
Safety Approval:	UL US

Part Number Configuration.
For More Details, go to next page(s)

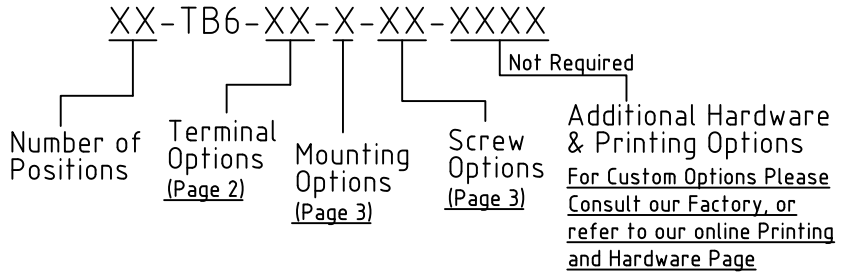

Max Number of Positions = 30

UNLESS OTHERWISE SPECIFIED BREAK ALL SHARP EDGES AND DEBURR ALL HOLES

TITLE: 0.375" SPACING, BARRIER BLOCK

LIMITS: UNLESS OTHERWISE SPECIFIED HUND.±.02 FRACT.±1/64 THOU.±.005 ANGLE±1°	SCALE	THIS IS A CONFIDENTIAL DRAWING AND MUSTBE TREATED AS SUCH. NO DISTRIBUTION IS ALLOWED WITHOUT WRITTEN APPROVAL BY EBYP ELECTRO INC.	Electro Inc. PLAINVIEW, NY 11803
---	-------	---	-------------------------------------

IMPORTANT DISCLAIMER: All information provided on this print is for reference. Always perform your own tests and acquire samples and further information to determine product suitability. While we make effort to provide accurate information, we cannot be responsible for errors either of omission or typographical. EBYP Electro, Inc. assumes no responsibility for the use or suitability of any product. All products and specifications are subject to change without prior written notice.

METRIC LIMITS ONE PLACE ±0.3 TWO PLACES ±0.10 ANGLE ±1°	DRAWN JM CHECKED APPROVED	DATE 10/26/10 DATE DATE	SIZE A	DRAWING NUMBER: TB6-0001	REV.
--	---------------------------------	-------------------------------	-----------	-----------------------------	------

PC - Standard PC

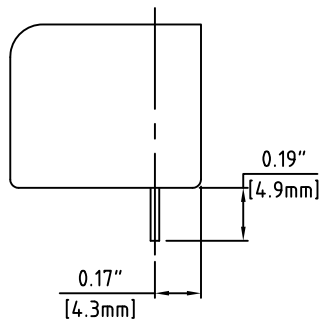

RA - Right Angle

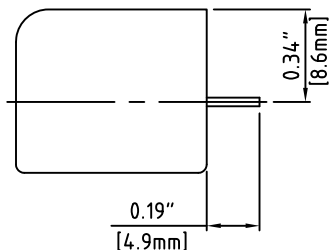

DL - Dual PC Legs

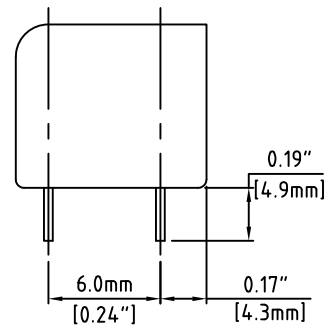

SV - Solder Turret

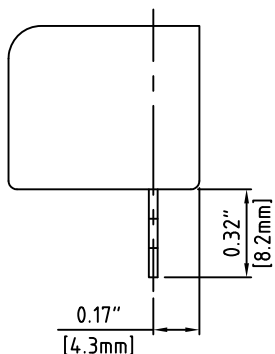

SR - Right Angle Solder Turret

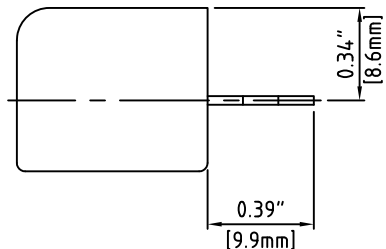

SS - Short PC

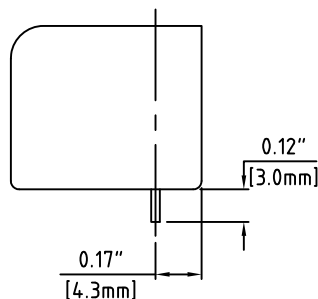

WW - Wire Wrap

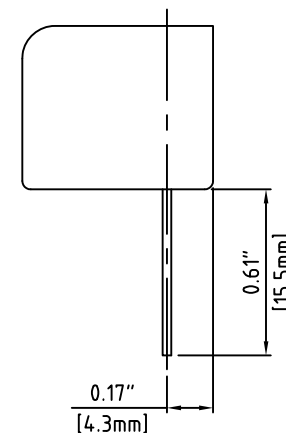

Terminal Options

UNLESS OTHERWISE SPECIFIED BREAK ALL SHARP EDGES AND DEBURR ALL HOLES

TITLE: Part Number Configuration for TB6 Series

LIMITS: UNLESS OTHERWISE SPECIFIED
 HUND. ± 0.2 FRACT. ± 1/64
 THOU. ± 0.005 ANGLE ± 1°

SCALE THIS IS A CONFIDENTIAL DRAWING AND MUST BE TREATED AS SUCH. NO DISTRIBUTION IS ALLOWED WITHOUT WRITTEN APPROVAL BY EBYP ELECTRO INC.



IMPORTANT DISCLAIMER: All information provided on this print is for reference. Always perform your own tests and acquire samples and further information to determine product suitability. While we make effort to provide accurate information, we cannot be responsible for errors either of omission or typographical. EBYP Electro, Inc. assumes no responsibility for the use or suitability of any product. All products and specifications are subject to change without prior written notice.

METRIC LIMITS
 ONE PLACE ± 0.3
 TWO PLACES ± 0.10
 ANGLE ± 1°

DRAWN JM DATE 10/26/10
 CHECKED _____ DATE _____
 APPROVED _____ DATE _____

SIZE A

DRAWING NUMBER: TB6-0002

REV.

Mounting Options

N - No Mounting

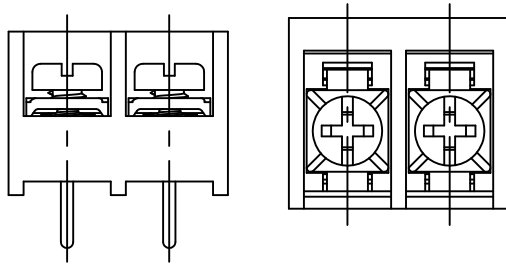

W - $\phi 0.158$ Mounting Hole

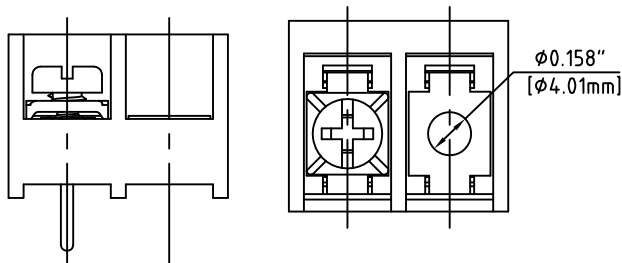

Available Screw Options

- 00 - No Screws
- 01 - Steel, Zinc Plated,
- 02 - steel, Zinc plated, w/ Washer
- 03 - Brass, Nickel Plated
- 04 - Brass, Nickel Plated, w/ Washer
- 05 - Stainless Steel, Phillips Head
- 11 - Steel, Zinc Plated, Captive
- 12 - Steel, Zinc Plated, Captive, w/ Washer
- 13 - Brass, Nickel Plated, Captive
- 14 - Brass, Nickel Plated, Captive, w/ Washer
- 21 - Steel, Zinc Plated, Captive, Wire Ready
- 22 - Steel, Zinc Plated, Captive, Wire Ready, w/ Washer
- 23 - Brass, Nickel Plated, Captive, Wire Ready
- 24 - Brass, Nickel Plated, Captive, Wire Ready, w/ Washer
- 46 - Steel, Zinc Plated, Thread Interrupt, Wire Ready, w/ Washer

UNLESS OTHERWISE SPECIFIED BREAK ALL SHARP EDGES AND DEBURR ALL HOLES

TITLE:
Part Number Configuration for TB6 Series

LIMITS: UNLESS OTHERWISE SPECIFIED
HUND. ± 0.2 FRACT. $\pm 1/64$
THOU. ± 0.005 ANGLE $\pm 1^\circ$

SCALE THIS IS A CONFIDENTIAL DRAWING AND MUSTBE TREATED AS SUCH. NO DISTRIBUTION IS ALLOWED WITHOUT WRITTEN APPROVAL BY EB Y ELECTRO INC.



IMPORTANT DISCLAIMER: All information provided on this print is for reference. Always perform your own tests and acquire samples and further information to determine product suitability. While we make effort to provide accurate information, we cannot be responsible for errors either of omission or typographical. EB Y Electro, Inc. assumes no responsibility for the use or suitability of any product. All products and specifications are subject to change without prior written notice.

METRIC LIMITS
ONE PLACE ± 0.3
TWO PLACES ± 0.10
ANGLE $\pm 1^\circ$

DRAWN JM DATE 10/26/10
CHECKED _____ DATE _____
APPROVED _____ DATE _____

SIZE
A

DRAWING NUMBER:
TB6-0003

REV.